



DIRECT STEAM LEG TILTING KETTLE

Job _____
Item# _____



MODEL	CAPACITY	
DLT-20	20 Gallon	76 Liter
DLT-30	30 Gallon	114 Liter
DLT-40	40 Gallon	151 Liter
DLT-60	60 Gallon	227 Liter
DLT-80	80 Gallon	303 Liter
DLT-100	100 Gallon	379 Liter

SPECIFICATIONS:

Shall be a Crown model _____, direct steam connected tri-leg tilting kettle. A double wall kettle interior shall form a steam jacket around the lower 2/3 of the kettle. The bottom of the kettle shall be of hemispherical design for superior heat circulation.

The tri-leg mounting frame of stainless steel pipe shall support the kettle and tilt console, conceal the steam piping and house the steam control valve and tilt mechanism. Each leg shall be fitted with a 4 hole adjustable flanged foot for securing to the floor. The tilt mechanism shall permit the kettle to tilt forward a full 90° for complete emptying. The tilting mechanism shall be self locking for positive stop action.

Construction shall be all welded #4 finish stainless steel type 304. The interior liner shall be standard 316 for high acid content cooking. Faucet bracket included.

OPERATION SHALL BE BY:

Direct steam at a minimum of 5 PSI (34kPa) and a maximum of 30 PSI (206kPa).

OPTIONAL ITEMS AT EXTRA COST:

- 50 PSI (345kPa) high pressure operation for higher cooking temperature
- 2" (50 mm) draw off-valve (TVT-2) with perforated strainer (TPS-)
- 3" (76 mm) draw off-valve (TVT-3) with perforated strainer (TPS-)
- Spring assist hinged cover for 20, 30 or 40 gallon models (CH-)
- Etched gallon markings (GM-)
- Etched litre markings(LM-)

ACCESSORIES:

- One piece lift off cover (C-)
- Triple basket assembly (TBA-)
- Steam trap assembly consisting of steam trap, steam control valve, check valve and line strainer (STA-1)
- Single pantry faucet with swing spout (SF-18)
- Double pantry faucet with swing spout (DF-18)
- Solid stainless steel disc for draw-off valve (TSS-)
- Graduated measuring strip (CMS-)
- Strainer hook (SH)
- Pan carrier (PC-4)



Models: DLT-20 DLT-30 DLT-40 DLT-60 DLT-80 DLT-100

MODEL	SHIPPING WEIGHT	MINIMUM CLEARANCE	
DLT-20	215 lbs. [98 kg]	SIDES	0 [0]
DLT-30	285 lbs. [129 kg]		
DLT-40	332 lbs. [151 kg]		
DLT-60	385 lbs. [177 kg]	BACK	0 [0]
DLT-80	424 lbs. [192 kg]		
DLT-100	480 lbs. [218 kg]		

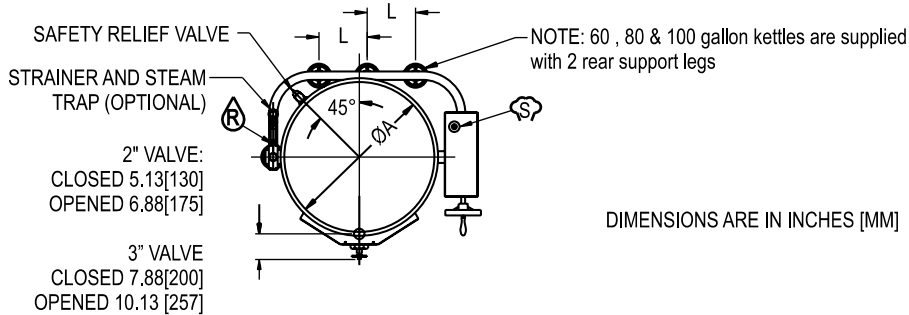

DIMENSIONS ARE IN INCHES [MM]



FLANGED FOOT DETAIL
4 EQUALLY SPACED
Ø7/16" [11mm] HOLES
ON 3 [76] B.C.

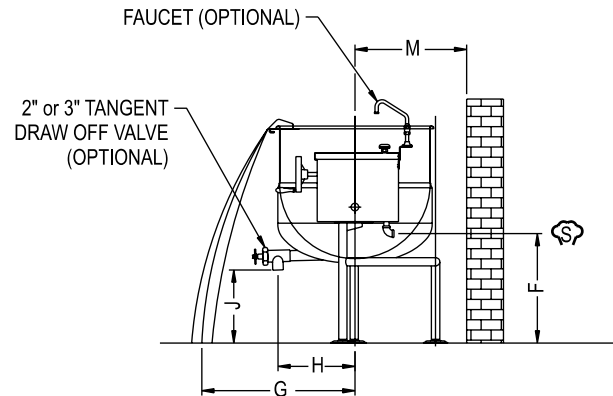
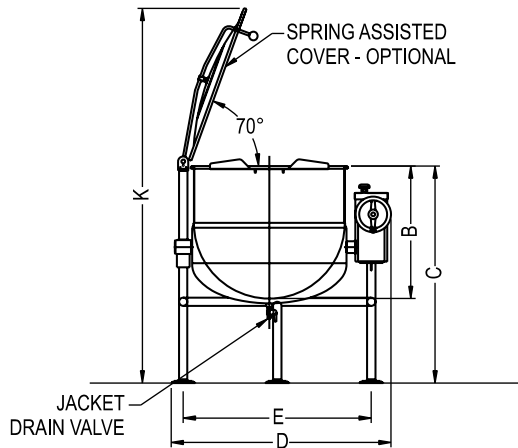

DIMENSIONS

MODEL	CAPACITY	UNITS	A	B	C	D	E	F	G	H(2")	H(3")	J(2")	J(3")	K	L	M
DLT-20	20 gallons (76 liters)	in (mm)	21" (533)	18" (460)	37" (940)	34.75" (885)	28.5" (724)	22" (559)	25.63" (651)	12" (305)	13.25" (337)	17" (432)	16.5" (419)	59.5" (1512)	N/A	15.38" (391)
DLT-30	30 gallons (114 liters)	in (mm)	24" (610)	20" (510)	37" (940)	37.75" (960)	31.5" (800)	20.75" (527)	27.13" (689)	12.5" (317)	14.25" (362)	15" (381)	14.5" (368)	62.5" (1588)	N/A	15.38" (391)
DLT-40	40 gallons (152 liters)	in (mm)	26" (660)	22.5" (570)	37" (940)	39.75" (1010)	33.5" (850)	20.25" (514)	28.63" (727)	13" (330)	15.25" (387)	12.5" (318)	12" (305)	64" (1626)	N/A	16.38" (416)
DLT-60	60 gallons (227 liters)	in (mm)	29.5" (750)	26" (660)	40.5" (1029)	43.25" (1100)	37" (940)	21.5" (546)	30.13" (765)	13.75" (350)	15.5" (394)	14.5" (368)	14" (356)	74" (1879)	9.5" (241)	18.38" (467)
DLT-80	80 gallons (303 liters)	in (mm)	33" (840)	28" (710)	42.5" (1080)	46.75" (1085)	40.5" (1030)	20" (508)	32.63" (828)	14.5" (368)	16.25" (413)	12.5" (318)	12" (305)	76" (1930)	11" (279)	19.88" (505)
DLT-100	100 gallons (379 liters)	in (mm)	35.5" (902)	30" (762)	42.5" (1080)	49.25" (1251)	43" (1092)	27" (686)	39.25" (997)	18" (457)	20.25" (514)	10.5" (267)	10" (254)	79" (2007)	12.5" (318)	21.5" (546)

SERVICE CONNECTIONS

☁ - STEAM SUPPLY: 3/4" IPS (19 mm) 5-30 PSI (34-206 kPa). Optional 5-45 PSI (34-310 kPa).

Ⓡ - CONDENSATE RETURN: 1/2" IPS (13 mm)

**INTENDED FOR COMMERCIAL USE ONLY.
NOT FOR HOUSEHOLD USE.**



70 Oakdale Road, Toronto ON, Canada M3N 1V9
(919) 762-1000 www.crownsteamgroup.com